

Technical Mathematics: Biotechnology and Environmental Technology¹

CRAFTY Curriculum Foundations Project
Los Angeles Pierce College, October 5-8, 2000
J. Sargeant Reynolds Community College, October 12-15, 2000

Report Editors: Elaine Johnson, John C. Peterson, and Kathy Yoshiwara
Workshop Organizers: Bruce Yoshiwara and Gwen Turbeville

SUMMARY

Our fields do not require a lot of advanced mathematics. Basic algebra and statistics are the mathematical topics required for students to complete a biotechnology or environmental AS or AAS program; environmental AS or AAS programs include some basic geometry and trigonometry as well. Courses in algebra and statistics should use an applications-based approach instead of the traditional textbook approach, considering real-life problems that demonstrate how mathematics is used in the field.

Mathematics should not be a filter that causes students to drop out of our programs. We have found that students do not take remedial courses and then return to the programs. Keep in mind the target population: These students may need more hands-on learning. Students tend to be turned-off by dry material. It is important that students learn to use mathematics as a tool, whether or not they “like” mathematics.

To enter the job market, students should master application of the topics listed in Appendices C or D. There is a critical need for more mastery of basics; more depth, less breadth; a need to build systematically on the basics. Mathematics courses should provide the fundamentals. Applications can then be integrated into specific Biotechnology and Environmental Technology courses.

Although there have been major and significant advances in biotechnology and environmental technology, these advances do not dictate the need for changes in the mathematics taught. Advances in technology have not eliminated the need for theoretical understanding. Students should not become too dependent on technology. They should question their answers, using common sense and estimation skills.

However, we do see a need for some changes in mathematics education for our students. Biology is more quantitative than it used to be, and experimentation is often based on databases. Statistics

¹ This material is based on work supported by the National Science Foundation under DUE grant no. 0003065. Any opinions, findings, and conclusions or recommendations expressed in this paper are those of the authors and do not necessarily reflect the views of the National Science Foundation.

must be integrated into the curriculum for technical AAS programs. Students should learn to use databases, manipulate database information, plot and interpret graphs, and present data to others using presentation software packages. More applications and more technology should be incorporated into mathematics courses and there should be more emphasis on teamwork and communication skills.

NARRATIVE

Introduction and Background

This report was compiled by representatives from associate degree programs in biotechnology and environmental technology and from the biomedical and environmental areas. In some cases biomedical engineering and biotechnology have been discussed separately, because, while there is some overlap between the two fields, there are also many differences.

Our fields do not require a lot of advanced mathematics (such as calculus and trigonometry). We agreed that everyone should know more mathematics than is required in their everyday job, but probably not calculus or advanced trigonometry.

Basic algebra and statistics are the mathematical topics required for students to complete a biotechnology or environmental AS or AAS program; environmental AS or AAS programs include some basic geometry and trigonometry as well. Courses in algebra and statistics should use an applications-based approach instead of the traditional textbook approach, considering real-life problems that demonstrate how mathematics is used in the field. Specific topics are listed in Appendices C and D.

Many biotechnology programs do not have a college mathematics requirement. However, chemistry is required for most biotechnology programs and it is common for chemistry to have mathematics requirements. Therefore, the prerequisite mathematics may be driven by chemistry.

There is a strong mandate requiring advanced mathematics, such as calculus, that comes from ABET² and articulation requirements with four-year colleges. This calculus requirement also has economic ramifications for institutions. However, there is little need for mathematics past algebra when people enter the workplace. Some trigonometry is needed, but probably not advanced trigonometry. In fact, while biomedical programs require far more mathematics than biotechnology programs, technicians in this field may in fact use less mathematics than biotechnologists.

Most environmental and biotechnology programs integrate mathematics into all their applied laboratory classes. Therefore, there is often applied mathematics instruction in most biotechnology and environmental courses.

General and Philosophical Comments

There is a need for more job awareness in the K-12 educational system. Students don't know what the biotechnology and environmental technology professions are like.

² ABET is the Accreditation Board for Engineering and Technology, Inc.

A question that came up repeatedly in our discussion is who should provide the mathematics instruction for our specific programs? Should mathematics be taught in the technical program itself, or should it be taught by the mathematics department? Should it be taught by “captive” mathematics instructors who work for the technical program?

For economic reasons, and to ensure that courses articulate with four-year schools, students from several technical programs are often combined into a single technical mathematics class. This makes it more difficult for the mathematics teacher to focus on discipline-specific applications. Should students from different programs be combined? We need to look at outcomes to see whether students in combined classes are successfully mastering the material they need.

A related question is how and where to incorporate mathematics into a program. Mathematics should not be a filter that causes students to drop out of our programs. If a student wants to enter a biotechnology program but has poor mathematics skills, and if we send that student to take basic mathematics before beginning program courses, most often we never see the student again.

Students do not take remedial courses and return to the programs. So, what should be the pathway for these students? Can they still move forward in the program? Sometimes students enter programs with poor backgrounds and become so motivated by the material that they are successful in mathematics. It is important to provide opportunities and not allow mathematics entry requirements to be a barrier.

Many students entering the biomedical engineering technology field have good mathematics skills and/or like mathematics. This ability is what motivates them to enter an engineering technology program. On the other hand, biotechnology students may not like mathematics and may have poor skills in mathematics. In environmental programs, we have found no consistent attitude toward mathematics. In any case, it is critical that students learn to use mathematics as a tool, whether or not they “like” mathematics.

Understanding and Content

What mathematics is needed in order to complete an applied associate or associate degree and to enter the job market?

A. Biomedical Engineering Technology

Our workgroup unanimously agreed that courses in college algebra and elementary statistics are vital to successful completion of an AAS program. These courses establish the foundation on which technical courses build. The workshop participants in Biotechnology and Environmental Technology have identified specific mathematical topics they considered essential to their areas. These topics are listed by priority in Appendices C and D. (Note: Low priority does not mean that understanding of the topic is not needed.)

To enter the job market, students should master application of the topics listed in Appendix C or D. Mathematics courses should provide the fundamentals, and applications can then be integrated into specific Biotechnology and Environmental Technology courses. However, both academia and

industry are finding the need to re-teach fundamentals of algebra and statistics in more advanced courses, as well as on the job.

The industry representative listed the following topics necessary for the Associate's Degree, entry into the job market, and career advancement. The referenced problems are in Appendix F.

- Fractions (See problems 1-14)
- Algebra and trigonometric identities (See problem 3)
- Fundamental operations and conversions (See problems 1-14)
- Formula manipulation (See problems 1-14)
- Word problems (See problems 1, 2, 3, 4 and 6)
- Rounding
- Functions and graphs (See problems 1, 2 and 4)
- Linear equations (See problem 5)
- Determinants (See problem 5)
- Trigonometric functions (See problem 3)
 - Angles
 - Right triangles
 - Oblique triangles
- Vectors (See problem 3)
- Quadratic equations (See problem 5)
- Radians and degrees
- Rectangular and polar coordinates
- Boolean algebra (See problem 6)

Students interested in completing a Bachelor's Degree should also complete coursework in calculus. (Any TAC-ABET accredited Associate's program in Biomedical Engineering Technology must include calculus in its degree requirements.)

B. Biotechnology

Biotechnology technicians must have basic knowledge of many mathematical topics and extensive experience in application. Problems illustrating the topics below can be found in Appendix F.

Algebra

- Percentages (See problem 1)
- Ratios and proportions (See problem 2)
- Dilutions and concentration calculations (See problems 3, 4 and 5)
- Measurements
- Metric system and metric conversions (See problem 6)
- Significant figures
- Scientific notation

Data manipulation and presentation

Graphing and interpretations of graphs of:

- Linear equations
- Quadratic equations
- Linear regression
- Exponential/logarithmic functions illustrated in log and semi-log plots (See problems 7 and 8)
- Complex functions (This does not mean working with complex numbers but we were not able to give an example of what was meant.)

Construction and use of a standard curve (See problem 9)

Computer software applications

Generating and understanding data spreadsheets

Graphing software

Data base entry and manipulation

Statistics

Sampling, sample size, mean and mode

Histograms (See problem 10)

Standard deviations (See problem 10)

Normal and bimodal distribution (See problem 11)

Statistical significance

Chi-squares

P values

Statistical controls (See problem 12)

Evaluation of data and measurement systems (See problems 13 and 14)

What mathematics is needed to climb the career ladder?

A. Biomedical Engineering Technology

In biomedical engineering, all workers take advanced service courses. Industry requires engineers to have a baccalaureate or higher degree, but not all technicians need education beyond the AS or AAS level. (This brings up the issue of the transferability of an applied or technical mathematics course to a 4-year institution. This issue is discussed further in response to the next question.)

Graduates tend to move into management in hospitals with the associate degree. They may take business and management courses to advance. Nursing combined with a biomedical degree is very advantageous. Companies really like these people. A graduate who wants to become an engineer will need a BS degree. Thus, moving up the career ladder and getting further education are not necessarily the same.

B. Biotechnology

In biotechnology, employees are often sent back to school to learn what they need to know, such as computers or mathematics. In biomanufacturing, people may be able to advance without further degrees. Bioprocessing technicians will probably need more education in computers; they are less likely to need more mathematics. For R&D (research and development) and for QC/QA (quality control/quality assurance), there is a strong feeling that people need at least a BS degree in order to advance. Therefore, there is pressure for students to take calculus, since it is typically required for a biology BS degree. No one at the workshop could think of a reason why calculus is actually needed, except that it is required for a BS degree. In the work place, statistics and experimental design would be helpful.

In the environmental field, technicians can be employed in jobs ranging from environmental sampler to hazard waste coordinator or environmental manager. However, more education means more upward mobility. There are several 4-year degree programs that have environmental emphasis, including environmental science, environmental biology, environmental chemistry,

environmental geology, environmental toxicology, environmental engineering, and environmental management.

Historically, 4-year institutions require a minimum of college algebra and statistics. If mathematics courses were developed for specific applications, they would probably not be transferable towards a baccalaureate degree program. Therefore, a student who is required to complete a non-traditional applied or technical mathematics course for the AS or AAS program will most likely be required to take traditional college algebra and statistics to fulfill the mathematics requirements for a baccalaureate degree program.

What priorities exist among these topics?

Mastery of certain skills is critical. This includes performing calculations related to percentages, dilutions, solutions, concentration, exponents, scientific notation, and basic algebra. Students must practice these skills over and over again. Mastery of the basics is more important than exposure to a lot of mathematics.

Students must be able to extract information from written materials, both data and the method for solving a problem. They must be able to apply what they have read to their own problems. They must be able to solve word problems. They must be able to extract numerical information in the laboratory and solve problems using that information.

As people advance up a career ladder they may need more mathematics skills, particularly if they move into research or engineering.

Specific topics relevant to Biotechnology and Environmental Technology are prioritized in Appendix C. The workshop participants identified these topics and ranked them according to the importance of their applications.

Examples:

1. Situation: A laboratory technician collects water samples and must test the samples for their chloride content. The technician needs to understand the concepts of random versus non-random sampling and the relevance of sample size on the interpretation of the testing results.
2. The testing requires a chloride standard to be diluted several ways in order to test various known concentrations of the standard using a defined test method. The technician needs to understand fractions and accuracy of measurements.
3. The standards and the samples are analyzed using the defined test method and a standard curve is obtained for the various known concentrations of the chloride standard. The technician needs to know how to plot data, recognize the shape of the curve, identify outliers and apply linear regression analysis.
4. The chloride content of the samples (unknown) is determined from the standard curve. The technician needs to know the relationship between x and y (how to use the linear regression formula).

What is the desired balance between theoretical understanding and computational skill? How is this balance achieved?

The student's first priority is to solve applied problems in the laboratory. Minimal theory is required, such as is taught in high school algebra. If a person moves into research, then he or she will probably need more theory. In production, technicians need only very simple multiplication and division skills.

Technology

The technician must be able to solve numerical problems using databases, use the Internet to connect to national databases, and manipulate database information. For example, the technician might look at correlations or percent differences in genome sequences.

In general students should be able to use ordinary and statistical calculators and should become comfortable with spreadsheets for calculation and graphing. However, they should not become too dependent on technology. They should question their answers, not accept them blindly. Students should use common sense and estimation skills.

Students should understand software associated with equipment; programming instruments is important. There may be statistics associated with using instruments.

Future Trends

With proteomics and genomics, students need more instruction in information sciences. There has been rapid growth in bioprocessing. In Genentech, for example, there are ten jobs in bioprocessing for each job in R&D. Technicians need to be comfortable with some engineering. They may need some electronics and knowledge of HVAC systems. They need to know how to fix and operate instruments. The ability to operate instruments is more important for AAS graduates than knowing the mathematics and engineering behind the instruments. Twenty years ago technology became hugely important in nursing, and people needed to learn about this technology, so they invented a field to create liaisons between technology and clinicians. Robotics is now becoming a big issue. Technicians need to be able to install instruments without instruction.

Instructional Techniques

What are the effects of different instructional methods in mathematics on students in your discipline?

Much of this has been discussed above. Keep in mind the target population: These students may need more hands-on learning. Students tend to be turned-off by dry material.

What instructional methods best develop the mathematical comprehension needed for your discipline?

In addition to what was discussed above, real life examples, verbal examples of logic (valid and invalid reasoning), and hands-on use of technology are most effective.

Instructional Interconnections

What changes have occurred in your discipline that should affect what mathematics is taught?

Although there have been major and significant advances in biotechnology and environmental technology, these advances do not dictate the need for changes in the mathematics taught. Advances in technology have not eliminated the need for theoretical understanding. Unfortunately, advances in technology have reduced the requirement for computational skills, and it is apparent that the youth of today's society lack even the most basic computational skills (multiplication and division), due to the acceptance of calculators in primary and secondary schools. The widespread use and acceptance of computers and computerized equipment further reduce the level of computational skills. It is also worth noting that the application of computational skills may reinforce theoretical understanding.

We recommend that mathematics faculty coordinate with technology faculty on a periodic basis to keep abreast of any changes that might affect what mathematics topics are taught. In particular, we see the following eight changes that should affect what mathematics is taught.

1. Volumes are usually small with units such as micro (microliter), nano (nanoliter), pico (picoliter), but can include 1000s or kilos (kiloliters). Small and large scales affect math.
2. Bioinformatics and computer technologies
3. Biology is more quantitative than it used to be.
4. Experimentation is often based on databases.
5. People tend to move more across different disciplines
6. Regulatory affairs have brought in more statistics
7. Teamwork is more important in the workplace
8. There may be more acceptance in the profession of people with skills instead of degrees

What changes have occurred in your discipline that should affect how mathematics is taught?

Advances in technology, computer programs, and equipment in our discipline drive the need for using software programs and databases such as Lotus 123, Oracle, Excel, etc. in the classroom. These are tools commonly used in industry. We see the following seven changes that should affect how mathematics is taught.

1. More teamwork in solving mathematics, since there is a need in the workplace for this skill
2. More oral communication/presentation skills required to present work, such as graphs
3. More use of computers to present information, to get information (including use of Internet) and to plot data
4. Interpretation of graphs, ability to plot or show data in many different ways
5. Capability to make computer presentations means students are expected to display data in more ways, using computers to make it look good.
6. System level troubleshooting is now more important than individual instruments. It often costs too much to fix an individual instrument, so technicians just replace the whole thing. Boards are cheaper and complex, so technicians don't trouble-shoot them.

7. Technicians need enough computer literacy skills to learn new software packages, so use a variety of software packages in mathematics instruction.

The group disagreed on whether it is more important to be flexible in using various software packages, or to know specific commonly used software packages. It might be helpful for mathematics instructors to use whatever packages are most commonly used in biotechnology programs.

What changes are needed in the mathematics curriculum in order to satisfy the needs of AAS students and technicians?

1. Statistics must be integrated into the curriculum for technical AAS programs.
2. The biggest need is for more applications and more technology incorporated into mathematics courses
3. Word application problems need to be used more throughout the topics taught.
4. There is a critical need for more mastery of basics; more depth, less breadth; a need to build systematically on the basics. Mastery requires repetition, and is different than exposing student to lots of material. Mastery also involves making sure students can apply mathematics in their own field.
5. Students should learn how to present data to others using presentation tools (computer tools) and speaking skills.
6. Estimation with a particular system should be taught. For example, estimate how many basketballs would fit in a room? How long will it take to get enough material to sequence a gene? Estimation helps students know if their results make any sense when they use a calculator or computer.
7. Many students go into technical fields because they are hands-on people. Teachers need to respond to students who may be very kinesthetic and to make instruction hands-on and interesting.
8. Teachers should use projects involving multiple mathematics skills that also tie in technical content. For example, figure out a correlation between sequence and function based on genome data base information, or calculate enzyme activity based on laboratory data.
9. Changes in the assessment of student competencies should also be considered.

What instructional methods might mathematics instructors use to develop or reinforce non-mathematical skills or understandings in your discipline or company?

1. Use a lot of teamwork in classes.
2. Have students bring in their own problems with their own data, particularly if working with older students who have more background. Have students find data from journals or publications. Have students find the ways in which mathematics is applied.
3. Reinforce writing skills and deductive reasoning by requiring students to write an explanation of how they arrived at their result or answer and how they interpreted their results.
4. Ask students to predict a non-exact result (example: given a problem, will the result be greater than or less than a value).

5. Teach students while they are sitting in a circle; this arrangement sets up a different dynamic.
6. Let students practice teaching themselves; use peer mentoring.

How can dialogue on educational issues between your discipline and mathematics best be maintained?

Maintain an open line of communication through planned classroom visitations (guest speakers from industry, AS or AAS program faculty), conduct surveys and hold local workshops with industry representatives and AS or AAS program faculty. Here are nine ways in which this can be accomplished:

1. Have industry people work to connect mathematics teachers with jobs.
2. Have advisory groups from industry or technical faculty work with mathematics teachers, have mathematics teachers on biotechnology program faculty.
3. Acquaint mathematics teachers with work keys, SCANS, and occupational skill standards.
4. Have discipline-specific people present talks at mathematics meetings.
5. Have mathematicians and biotechnologists work on more complex project-based problems. Problems could involve genomic information, or interesting applications from news.
6. Bio-Link and other biotechnology instructors could act as a bridge to help mathematics teachers see real world applications, for example, in the human genome project. There could be collaboration between AMATYC and Bio-Link.
7. Encourage team teaching between mathematics and technical program teachers.
8. Have guest lecturers come to talk about how mathematics is used in their profession.
9. Have a mathematics teacher go to industry and review the mathematics currently being used in companies.

REFERENCES

Cincinnati State Technical and Community College Catalog, 3520 Central Parkway, Cincinnati, Ohio 45223.

Seidman, Lisa A. and Cynthia J. Moore. Basic Laboratory methods for Biotechnology: Textbook and Laboratory Reference. Upper Saddle River, NJ: Prentice Hall, 2000.

U.S. Department of Labor, Bureau of Labor Statistics. Occupational Outlook Handbook Online. <http://www.bls.gov>

WORKSHOP PARTICIPANTS

Brenda Breeding, Professor of Biology, Oklahoma City Community College, Oklahoma City, Oklahoma.

Daniel R. Brown, Ph.D., Lead Instructor of Microbiology and Biotechnology, Santa Fe Community College, Gainesville, Florida.

Sybil Chandler, Lead faculty for the Environmental Health and Safety Technology Associate Degree program of Metropolitan Community College's (MCC) Maple Woods Community College in Kansas City, Missouri.

Lois Dinterman, Director of Bioprocessing for Biorex, Inc., Pittsboro, North Carolina.

Linnea Fletcher, Ph.D., Austin Community College, Austin, Texas, and South Central Regional Director for Bio-Link

Leland Grooms, adjunct faculty and advisory committee member who assisted in the development for Environmental Sciences and EHS for Haskell Indian University, Lawrence, Kansas and Maple Woods Community College, respectively.

Elaine Johnson, Ph.D., City College of San Francisco, San Francisco, California, and National Director for Bio-Link an Advanced Technological Education (ATE) Center of Excellence of the National Science Foundation

Wendie Johnston, Ph.D., Pasadena City College, Pasadena, California: Program Director and Ed>Net Director

JoAnne Marzowski, Ph.D., Bristol Myers Squibb, Oncogene, Seattle, Washington: Researcher in molecular biology

Donald McAfee, Ph.D., Chair and CEO of Discovery Therapeutics, Inc., Richmond, Virginia, a pharmaceutical drug discovery and drug developing therapeutics for cardio-renal indications.

Jim McGillem, Biomedical, Facility Director, St. Mary's Warrick health care facility, Boonville, Indiana

Lisa Seidman, Ph.D., Madison Area Technical College, Madison, Wisconsin: Biotechnology Program and North Central Regional Director for Bio-Link

William H. Woodruff, Department Head, Biotechnology Department, Alamance Community College, Graham, North Carolina, and Southeast Regional Director for the BioLink Advance Technology Bio-Link Advanced Technological

Steve Yelton, Cincinnati State Technical and Community College, Cincinnati, Ohio: Program Chair, Electronics, Biomedical Electronics & Computer Network Engineering Technology,

ACKNOWLEDGEMENTS

The members of the panels would like to thank Bruce Yoshiwara, of Los Angeles Pierce Community College and Gwen Turbeville of J. Sargeant Reynolds Community College for coordinating the workshops at their respective campus. We would also like to thank the Mathematical Association of America for initiating this series of workshops and the American Mathematical Association of Two-Year Colleges for providing this opportunity to consider and make recommendations on a topic of importance to the information technology community, especially project directors Mary Ann Hovis, Rob L. Kimball, and John C. Peterson. Finally, we would like to thank the National Science Foundation for providing the funds to support these meetings.

Curriculum Foundations Project
APPENDIX A: Definitions.

The following definitions will help those who are not familiar with the fields of biotechnology and environmental technology to understand our report more fully.

Bioinformatics: A field of science formed by the merging of biology, computer science, and information technology.

Bioreactor: A piece of equipment used to produce products such as pharmaceuticals using live organisms.

Prokaryotic organisms: Single-cell organisms, such as bacteria, that lack a true membrane-bound nucleus and whose DNA is usually a single molecule.

Eukaryotic organisms: Organisms such as plants and animals made up of cells that contain a true membrane-bound nucleus.

Bioprocessing: The manufacturing of products using living cells.

Genome: The total complement of genes in an organism.

DNA: Deoxyribonucleic acid: a polymer that is part of chromosomes that contain the genetic code.

SCANS: The Secretary's Commission on Achieving Necessary Skills for the workplace.

APPENDIX B: Description of Programs.

In this document we discuss people preparing to work in one of three major areas: (a) Biotechnology, (2) Biomedical Electronics Engineering Technology, or (3) Environmental Health and Safety.

Biotechnology

Biotechnology is composed of many technical fields, and graduates of biotechnology AS or AAS programs can choose from many different jobs. For example, one graduate may be working on designing a new bioreactor, another may be developing a new assay, and still another may work in production or quality control. Therefore, the breadth and depth of the mathematical expertise one needs is determined by the specific technical field.

A general description of biotechnology programs follows: Biotechnology programs provide education for entry-level technicians in the biotechnology industry. The steady growth of biotechnology and related industries has resulted in the demand for highly skilled technicians. Biotechnology programs prepare skilled technicians to work at the entry level in a wide variety of scientific fields, including: research and discovery laboratories, service and quality assurance laboratories, food, water, soil and product testing laboratories and manufacturing facilities. Skills necessary to support these activities include knowledge of regulatory affairs, tissue culture of plant and animal cells, production with bacterial, yeast, mammalian and plant cells, molecular biology techniques, quality assurance, business, electronics, technical writing, web management, library science, computer science, chemistry, biochemistry, biology, microbiology, physics, analytical

laboratory techniques, laboratory instrumentation, growth, isolation and characterization of prokaryotic and eukaryotic organisms, histologic techniques, and immunological techniques.

Biomedical Electronics Engineering Technology

From the catalogue of Cincinnati State College:

The Biomedical Electronics Engineering Program (BMET) was created because of the need for technicians who repair, maintain, modify and design complex medical instrumentation. This person is employed in hospitals as well as medical equipment manufacturers. The BMET graduate will have advanced electronic skills as well as education in the following areas:

- installation and calibration of biomedical equipment

- operation of safety and maintenance programs

The biomedical electronics technician is a professional whose broad background in electronics and instrumentation will make the graduate an asset to any organization.

* * * * *

Starting salary for BMET graduates is about \$30–35,000 in biomedical engineering. Graduates have an opportunity to make \$70,000 if they can repair sophisticated medical, imaging, or laboratory equipment, but some of these jobs require a lot of traveling. Later, when they are tired of traveling, job opportunities may exist in a hospital although the hours are not ideal. However, \$40–50K job opportunities may exist with better working hours.

Environmental Health and Safety

Environmental Health and Safety provides a foundation in aspects of environmental health and safety technology including emergency response planning, OSHA, EPA, and DOT standards and legislation, air- and water-quality management, accident and incident investigation, characteristics and hazards of hazardous material, and working on hazardous waste sites. In addition, emphasis is placed on managing chemical and biological substances and studying their effects on the environment. The AAS degree program includes additional course work in chemistry, biology and physics.

The median salary of inspectors and compliance officers in environmental health and safety was over \$34,000 in 1994, with 10% of these jobs commanding salaries of about \$60,000.

Environmental health and safety careers offer good salary and opportunity. According to Dept. of Labor statistics, employment in the environmental, health and safety fields will grow through the year 2005, spurred by public demand for a livable environment, safe working conditions and non-hazardous consumer products.

There is a wide range of employment opportunity. The primary employers are industry, environmental consultants, and all levels of the government. Specialists are in demand in a wide range of fields including agriculture, aviation, electronics, health care, lumber, manufacturing, municipalities, park systems, petroleum, and local and Federal government.

Description of Students

We maintain open entry into almost all our technical programs; therefore students come in with very diverse mathematics backgrounds and abilities. In some programs a large percentage of the students enter with BS degrees, while other programs have few such students. There is still a gender difference. Biotechnology programs may have more women; environmental and engineering may have more men. The average age in community college programs is about 28, and many people are retraining.

APPENDIX C: Biotechnology

References:

Basic Laboratory Methods for Biotechnology
Textbook and Laboratory Reference
ISBN: 0-13-795535-9

Technical Math
Robert Smith
ISBN: 0-8273-6808-9
Algebra application examples

3= high; 2=medium; 1=low

Subjects		Priority		
		1	2	3
Basic Algebra				
1.	Estimating the answer/Approximating/ Fuzzy Math			X
2.	Fractions			X
3.	Decimals			X
4.	Percents, Percentiles Rank, Interpretation of Percentile Ranks			X
5.	Graphs, Plotting, Bar and Lines			X
6.	Creating Lines, Graphs, Thresholds			X
7.	Measurements: Precision, Accuracy, and Tolerance			X
8.	Measurement Unit (length, mass, volume, distance, time, temperature)/ Unit Factorization (conversation)			X
9.	Metric and English conversation			X
10.	Word application problems			X
11.	Scales of Measure (nominal, ordinal, interval, ratio)			X
12.	Algebraic Expressions			X
13.	Signed numbers			X
14.	Powers and Roots			X
15.	Basic Algebraic Operations			X
16.	Linear and Quadratic Equations			X
17.	Formula and variation problems			X
18.	Ratio and Portions (Variation problems)			X
19.	Cartesian Coordinate System and Graphs of Linear Equations			X
20.	Systems of Equations			X
21.	Dilutions			X
22.	Molarity (Normality), pH			X
23.	Log functions and graph			X
24.	Valid and invalid reasoning			X
25.	Geometry & Trigonometry	X		
26.	Measurement of diameter, area	X		
27.	Calculation of volume	X		

Subjects		Priority		
		1	2	3
28.	Pythagorean Theorem	X		
Basic Statistics (Applied Statistics)				
29.	Variables and Constants (continuous and discrete variables)			X
30.	Qualitative, quantitative, symbolizing variable in computations			X
31.	Tabulating Data (frequency distributions)			X
Graphing Data (discrete & continuous data)				
32.	Histogram			X
33.	Frequency Polygon	X		
34.	Smoothed and Misleading Graphs	X		
35.	Describing the Shapes of Distributions			X
Measures of Central Tendency				
36.	Mode	X		
37.	Median			X
38.	Mean			X
39.	Properties of the Mean			X
40.	Measures of Variance (range, variance, standard deviation, relative deviation)			X
41.	Data Collection and graphing of collected data			X
42.	Considerations in Selecting a Measure of Central Tendency			
43.	Scale of Measurement			X
44.	Shape of Distribution		X	
45.	Normal Distribution (normal curve in both directions, distribution table, interpretation of scores, normal curve equivalents, T-scores)			X
46.	Sets (union, intersection, compliment), definition of probability, conditions, basic laws, such as A or B, not A, A and B, B given that A is a curve, independent and dependent event, mutual exclusive events Simple Binomial probability (success/failure) Basic understanding: high/ Application: low			X
Measures of Relationship				
47.	Characteristics of Associations Between Variables (Scatter Diagram, degrees and directions of association)			X
48.	Calculating a Correlation Coefficient (for example: Pearson Product Moment, Interpreting a Correlation Coefficient)			X
49.	Correlation/causation			X
50.	Scale of the Pearson r			X
51.	Range of X - and Y - variables			X
52.	Prediction and Simple Linear Regression			X
53.	Simple Linear Regression			X
54.	The Standard of Error of Estimate			
55.	Marginal and Conditional Distributions			X
56.	Samples and Estimation			X
Type of Samples				
57.	Non random Sample	X		
58.	Probability Sample		X	
59.	Sampling distribution (theory only)			X
60.	Central Limit Theorem		X	

Subjects		Priority		
		1	2	3
61.	Confidence intervals			X
62.	Accuracy, bias, and precision in sampling			X
63.	Obtaining a confidence interval with a t-distribution			X
Testing Hypotheses				
64.	General Steps			X
65.	Possible Errors of Statistical Decision: Type I and Type II		X	
t-distribution and t-test				
66.	relationship between the z- and t- statistics		X	
67.	degrees of freedom		X	
68.	characteristics of the t-distribution		X	
69.	testing hypotheses about means-using the t-distribution		X	
70.	testing the hypothesis $\mu = \text{some value}$		X	
71.	testing difference between means		X	
72.	differences between means for independent random samples from equally variable populations differences between means for dependent samples			X
73.	Chi-Square Distribution, Goodness of Fit, Independence (general case, 2x2 contingency table)			X

APPENDIX D: Environmental Technology

References:

Basic Laboratory Methods for Biotechnology
Textbook and Laboratory Reference
ISBN: 0-13-795535-9

Technical Math
Robert Smith
ISBN: 0-8273-6808-9
Algebra application examples

3= high; 2=medium; 1=low

Subjects		Priority		
		1	2	3
Basic Algebra				
1.	Estimating the answer/Approximating/ Fuzzy Math			X
2.	Fractions			X
3.	Decimals			X
4.	Percents, Percentiles Rank, Interpretation of Percentile Ranks			X
5.	Graphs, Plotting, Bar and Lines			X
6.	Creating Lines, Graphs, Thresholds			X
7.	Measurements: Precision, Accuracy, and Tolerance			X
8.	Measurement Unit (length, mass, volume, distance, time, temperature)/ Unit Factorization (conversation)			X
9.	Metric and English conversation			X
10.	Word application problems			X
11.	Scales of Measure (nominal, ordinal, interval, ratio)			X
12.	Algebraic Expressions		X	
13.	Signed numbers			X
14.	Powers and Roots			X
15.	Basic Algebraic Operations			X
16.	Linear and Quadratic Equations			X

Subjects		Priority		
		1	2	3
17.	Formula and variation problems			X
18.	Ratio and Portions (Variation problems)			X
19.	Cartesian Coordinate System and Graphs of Linear Equations			X
20.	Systems of Equations			X
21.	Dilutions			X
22.	Molarity (Normality), pH			X
23.	Log functions and graph		X	
24.	Valid and invalid reasoning			X
25.	Geometry & Trigonometry		X	
26.	Measurement of diameter, area		X	
27.	Calculation of volume		X	
28.	Pythagorean Theorem	X		
Basic Statistics (Applied Statistics)				
29.	Variables and Constants (continuous and discrete variables)			X
30.	Qualitative, quantitative, symbolizing variable in computations			X
31.	Tabulating Data (frequency distributions)			X
Graphing Data (discrete & continuous data)				
32.	Histogram			X
33.	Frequency Polygon	X		
34.	Smoothed and Misleading Graphs	X		
35.	Describing the Shapes of Distributions			X
Measures of Central Tendency				
36.	Mode			X
37.	Median			X
38.	Mean			X
39.	Properties of the Mean			X
40.	Measures of Variance (range, variance, standard deviation, relative deviation)			X
41.	Data Collection and graphing of collected data			X
Considerations in Selecting a Measure of Central Tendency				
42.	Scale of Measurement			X
43.	Shape of Distribution			X
44.	Normal Distribution (normal curve in both directions, distribution table, interpretation of scores, normal curve equivalents, T-scores)			X
45.	Sets (union, intersection, compliment), Definition of Probability, conditions, basic laws, such as A or B, not A, A and B, B given that A is a curve, independent and dependent event, mutual exclusive events Simple Binomial probability (success/failure) Basic understanding – high/ Application –Low			X
46.	Measures of Relationship			
47.	Characteristics of Associations Between Variables (Scatter Diagram, degrees and directions of association)			X
48.	Calculating a Correlation Coefficient (for example: Pearson Product Moment, Interpreting a Correlation Coefficient)			X
49.	Correlation/causation			X
50.	Scale of the Pearson r			X

Subjects		Priority		
		1	2	3
51.	Range of X- and Y- variables			X
52.	Prediction and Simple Linear Regression			X
53.	Simple Linear Regression			X
	The Standard of Error of Estimate			
54.	Marginal and Conditional Distributions			X
55.	Samples and Estimation			X
56.	Type of Samples			
57.	Non random Sample	X		
58.	Probability Sample		X	
59.	Sampling distribution (theory only)			X
60.	Central Limit Theorem		X	
61.	Confidence intervals			X
62.	Accuracy, bias, and precision in sampling			X
63.	Obtaining a confidence interval with a t-distribution			X
	Testing Hypotheses			
64.	General Steps			X
65.	Possible Errors of Statistical Decision: Type I and Type II		X	
	t-distribution and t-test			
66.	relationship between the z- and t-statistics		X	
67.	degrees of freedom		X	
68.	characteristics of the t-distribution		X	
69.	testing hypotheses about means-using the t-distribution		X	
70.	testing the hypothesis $\mu = \text{some value}$		X	
71.	testing difference between means			X
72.	differences between means for independent random samples from equally variable populations differences between means for dependent samples			X
73.	Chi-Square Distribution, Goodness of Fit, Independence (general case, 2x2 contingency table)		X	

APPENDIX E: Sample Biomedical Problems

1. A patient is connected to a medical device via two electrodes as shown below, each with a diameter of 10 cm. The maximum allowable leakage current is 0.005 amps (5 milliamps). Calculate the maximum voltage allowed across the electrode leads to maintain a safe current for the following conditions: (a) dry skin, (b) gel coated skin, and (c) penetrated skin. Assume $R_V = 200 \Omega$. Voltage = $I(R \text{ electrode 1} + R_V + R \text{ electrode 2})$.

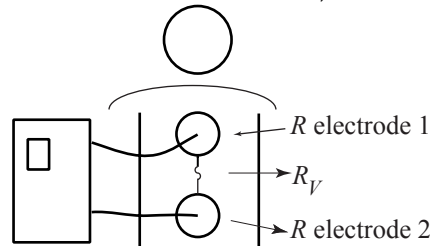

- A device was brought into the lab that had no output. There are no service manuals available for this device. Upon further investigation, you find a burned out capacitor, the value is unreadable. You find that the circuit looks like the one shown below. What should be the value of C to maintain less than 2 mV of ripple?

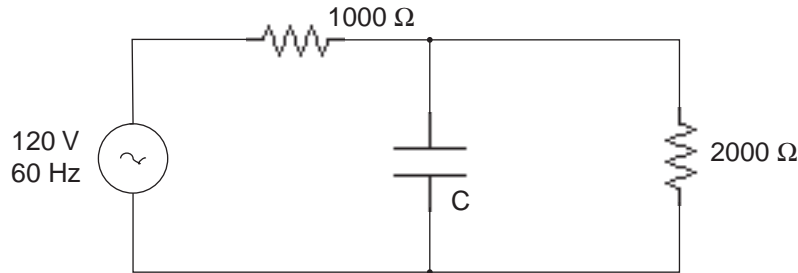

- A transducer is intended to be interfaced to a measuring device. The transducer produces a minimum sinusoidal output of 0.05 mV @ 1 μ A. The measuring device requires a minimum input of 10 mV. Design an amplifier that will perform this interface. Be sure to specify component types including part numbers.
- You are asked to design a resistive load to test output of a DC power supply. The power supply must be capable of producing 2 amps at 100 volts. The load must be designed with a 200% safety factor. Specify the value of the resistive load including resistance and power ratings.
- Using the diagram below, calculate currents I_{Total} , I_{R_2} , and I_{R_3} , voltage drop across R_4 , and the power dissipated across R_3 .

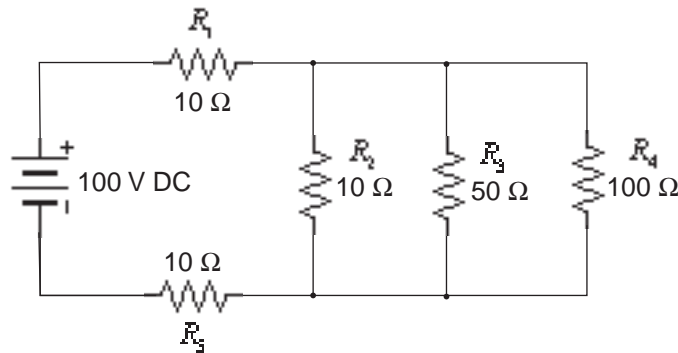

- An equipment cabinet must be protected by safety interlocks. There are two access panels with interlock switches. There is a key switch and there is a start button. When the access panel is open, the switch outputs a logic level 1, when closed, a 0. The only time that the process will start is when all panels are closed and the key switch is on. The key switch outputs a 1 in the on position. When these conditions are met, output a 1 to the “start process” line. If conditions are not met, output a 1 to the “system halted” line.

Generate a truth table to describe the process and design a circuit to produce the desired effect. The circuit should be the most simplified possible using Boolean algebra.

APPENDIX F: Sample Biotechnology Problems³

1. There are about 3×10^9 DNA base pairs in the human genome. Human chromosome 21 is the smallest chromosome (besides the Y chromosome) and contains about 2% of the human genome. About how many base pairs comprise chromosome 21?
2. If there are about 1×10^2 blood cells in a 1.0×10^{-2} mL sample, then about how many blood cells would be in 1.0 mL of this blood?
3. If the concentration of magnesium sulfate in a solution is 25 g/L, how much magnesium sulfate is present in 100 mL of this solution?
4. Suppose you have 20 μL of an expensive enzyme and you cannot afford to purchase more. The enzyme has a concentration of 1000 units/mL. You are going to do an experiment that requires tubes with a concentration of 1 unit/mL of enzyme and each tube will have 5 mL total volume. How much enzyme does each tube require? How many tubes can you prepare before you run out of enzyme?
5. A stock solution initially has a concentration of 20 mg of solute per liter. A diluted solution is prepared by removing 1 mL of stock solution and adding 14 mL of water. What is the concentration of solute in the diluted solution? How much solute is present in 1 mL of the diluted solution?
6. Suppose bacteria are growing in a flask. The growth medium for the bacteria requires 5 g of glucose per liter. A technician has prepared some medium and added 0.24 lb of glucose to 25 L. Did the technician make the broth correctly?
7. Cells in culture are treated in such a way that they are expected to take up a fragment of DNA containing a gene that codes for an enzyme. The activity of the enzyme in cells that take up the gene can be assayed. The more active the enzyme, the better. Suppose a researcher isolates 45 clones of treated cells and measures the enzyme activity in each clone. The results are shown in activity units.
 - a. Find the range, median, mean, and standard deviation for the data from these 45 treated clones.
 - b. Plot these data on a histogram and show on the plot where the mean and median are located.
 - c. Do you think the cells have taken up the gene fragment containing the enzyme, based on these data? Explain.
(45 data values follow)
8. A technician customarily counts the number of leaves on cloned plants. The results of nine such counts in successful experiments are:
75 54 55 61 71 67 51 77 71
If the technician obtains a count of 79, is this a cause for concern?
Perform statistical calculations to determine whether 79 leaves is out of the range of two standard deviations.

³ All examples in Appendix F are taken from Seidman and Moore's. *Basic Laboratory methods for Biotechnology: Textbook and Laboratory Reference.*

9. Consider a radioactive solution that has a half life of 1 hour and an activity of 400 disintegrations/minute initially. Figure 10.21(a) shows this phenomena graphed on a normal rectangular graph and Figure 10.21(b) shows the same data graphed on semilog paper. Discuss the advantages and disadvantages of each graph?

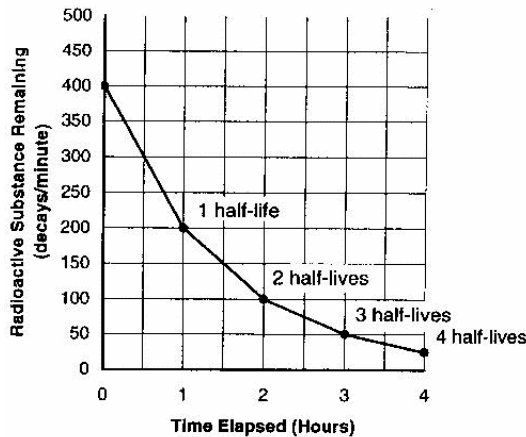

(a)

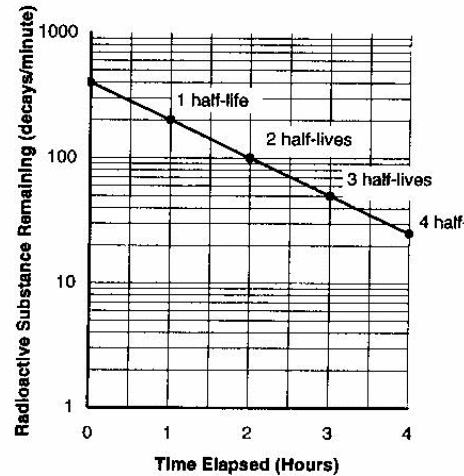

(b)

Figure 10.21. The Relationship Between Time Elapsed and Radioactivity Remaining. a. The relationship on normal graph paper. b. The relationship plotted on semilog paper.

10. It is difficult to kill all microorganisms in a material. A solution or material to be sterilized is typically heated under pressure. The following graph shows the effect of time of exposure to heat and bacterial death (based on information from Principles and Methods of Sterilization in the Health Sciences, John J. Perkins, 2nd edition, Charles C. Thomas, Springfield, 1983).

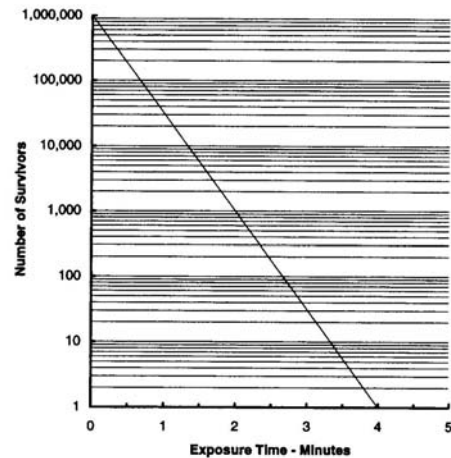

- About how many bacteria were there at the beginning of the experiment, before exposure to heat?
- About how many bacteria were present after 2 minutes of treatment?
- Why did the investigators show their data on a semilog plot?

11. Suppose you are planning to purchase a new micropipettor to pipette volumes in the 100 – 200 μL range. You consult a catalog and find the following information for 3 brands of pipettor: Brand A, Brand B, and Brand C. Based on the catalog specifications, which micropipettor is most accurate? Which micropipettor is most precise? Which would you purchase?

	Volume Range	Accuracy (Expressed as % Error)	Precision (CV)
Brand A	40 to 200 μL	$\pm 1\%$	0.5%

Brand B	100 to 200 μL	$\pm 0.5\%$	0.3%
Brand C	100 to 200 μL	$\pm 0.3\%$	0.4%

12. Which of the following frequency histograms most closely approximates a normal distribution? Which appears to be bimodal? Which appears skewed?

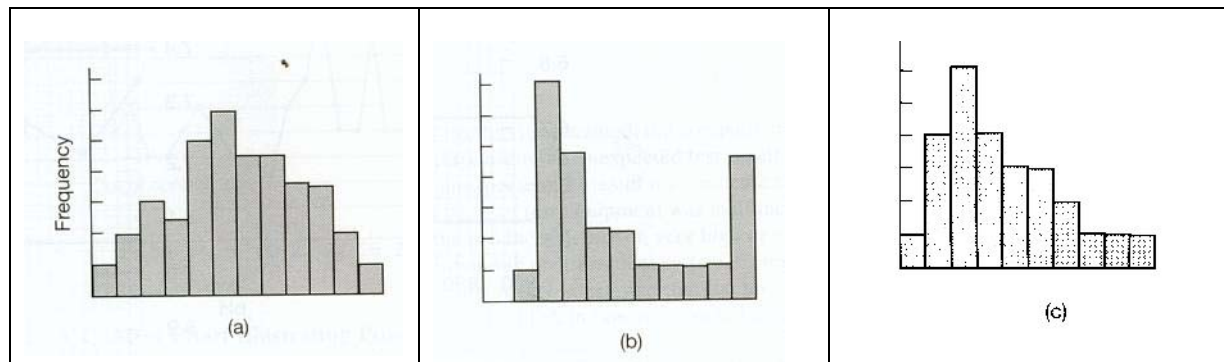

13. A biotechnology company manufactures a particular enzyme that is used to cut DNA strands. The enzyme's activity can be assayed and is reported in terms of "units/mg". Each batch of enzyme is tested before it is sold. The results of repeated tests on four batches of enzyme are shown in the table.
- What is the mean activity of the enzyme for each batch?
 - What is the SD for each batch?
 - What is the mean activity for all batches combined?
 - What is the SD for all batches combined?

Enzyme Activity (units/mg)			
Batch 1	Batch 2	Batch 3	Batch 4
100,900	100,800	110,000	123,000
102,000	101,000	108,000	121,000
104,000	100,100	107,000	119,000
104,100	100,800	109,100	121,000