

Design of an Oscillating Sprinkler

Bart Braden

Northern Kentucky University

Highland Heights, KY 41076

Mathematics Magazine, January 1985, Volume 58, Number 1, pp. 29–38.

The common oscillating lawn sprinkler has a hollow curved sprinkler arm, with a row of holes on top, which rocks slowly back and forth around a horizontal axis. Water issues from the holes in a family of streams, forming a curtain of water that sweeps back and forth to cover an approximately rectangular region of lawn. Can such a sprinkler be designed to spread water uniformly on a level lawn?

We break the analysis into three parts:

1. How should the sprinkler arm be curved so that streams issuing from evenly spaced holes along the curved arm will be evenly spaced when they strike the ground?
2. How should the rocking motion of the sprinkler arm be controlled so that each stream will deposit water uniformly along its path?
3. How can the power of the water passing through the sprinkler be used to drive the sprinkler arm in the desired motion?

The first two questions provide interesting applications of elementary differential equations. The third, an excursion into mechanical engineering, leads to an interesting family of plane curves which we've called curves of constant diameter. A serendipitous bonus is the surprisingly simple classification of these curves.

The following result, proved in most calculus textbooks, will play a fundamental role in our discussion.

LEMMA. Ignoring air resistance, a projectile shot upward from the ground with speed v at an angle θ from the vertical, will come down at a distance $(v^2/g)\sin 2\theta$. (Here g is the acceleration due to gravity.)

Note that $\theta = \pi/4$ gives the maximum projectile range, since then $\sin 2\theta = 1$.

Textbooks usually express the projectile range in terms of the "angle of elevation", $\pi/2 - \theta$; but since $\sin 2(\pi/2 - \theta) = \sin 2\theta$, the range formula is unaffected when the zenith angle is used instead.

The sprinkler arm curve

In Figure 1, a (half) sprinkler arm is shown in a vertical plane, which we take to be the xy plane throughout this section. Let L be the length of the arc from the center of the sprinkler arm to the outermost hole, and let $x = x(s)$, $y = y(s)$ be parametric equations for the curve, using the arc length s , $0 \leq s \leq L$, as parameter. Let $\alpha(s)$ denote the angle between the vertical and the outward normal to the arc at the point $(x(s), y(s))$.

We'll see that the functions $x(s)$ and $y(s)$ which define the curve are completely determined (once L , $\alpha(L)$ and $y(0)$ have been chosen) by the requirement that streams passing through evenly-spaced holes on the sprinkler arm should be uniformly spaced

when they strike the ground.

If there were a hole at the point $(x(s), y(s))$ on the sprinkler arm, the direction vector of the stream issuing from this hole would be $N(s) = \langle \sin \alpha(s), \cos \alpha(s) \rangle$, and this stream would reach the ground at a distance

$$d(s) = \frac{v^2}{g} \sin 2\alpha(s).$$

The condition that evenly-spaced holes along the arm produce streams which are evenly spaced when they reach the ground is that $d(s)$ be proportional to s :

$$\frac{d(s)}{d(L)} = \frac{s}{L},$$

or equivalently,

$$\sin 2\alpha(s) = \frac{s}{L} \sin 2\alpha(L). \quad (1)$$

(We have made the assumption that the dimensions of the sprinkler are small in comparison to the dimensions of the area watered. This simplifies the calculations, and the errors introduced are not significant.)

The unit tangent vector to the sprinkler arm curve at $(x(s), y(s))$ is $T(s) = \langle x'(s), y'(s) \rangle$, so the unit outward normal vector (obtained by rotating $T(s)$ counterclockwise by $\pi/2$) is $N(s) = \langle -y'(s), x'(s) \rangle$. Comparing this with our earlier expression for $N(s)$, we have

$$x'(s) = \cos \alpha(s), \quad y'(s) = -\sin \alpha(s).$$

Since $\sin 2\alpha(s) = 2 \sin \alpha(s) \cos \alpha(s)$, equation (1) for the sprinkler arm curve becomes

$$-2x'(s)y'(s) = \frac{s}{L} \sin 2\alpha(L).$$

The value of $\alpha(L)$, the angle between the vertical and the outermost stream as it leaves the sprinkler, is a parameter under the designer's control; once it is chosen, the value of $\sin 2\alpha(L)$ is determined—call it k , where $0 < k \leq 1$. Our equation then becomes

$$x'(s)y'(s) = \frac{-k}{2L} s. \quad (2)$$

Since $N(s)$ is a unit vector, also

$$x'(s)^2 + y'(s)^2 = 1. \quad (3)$$

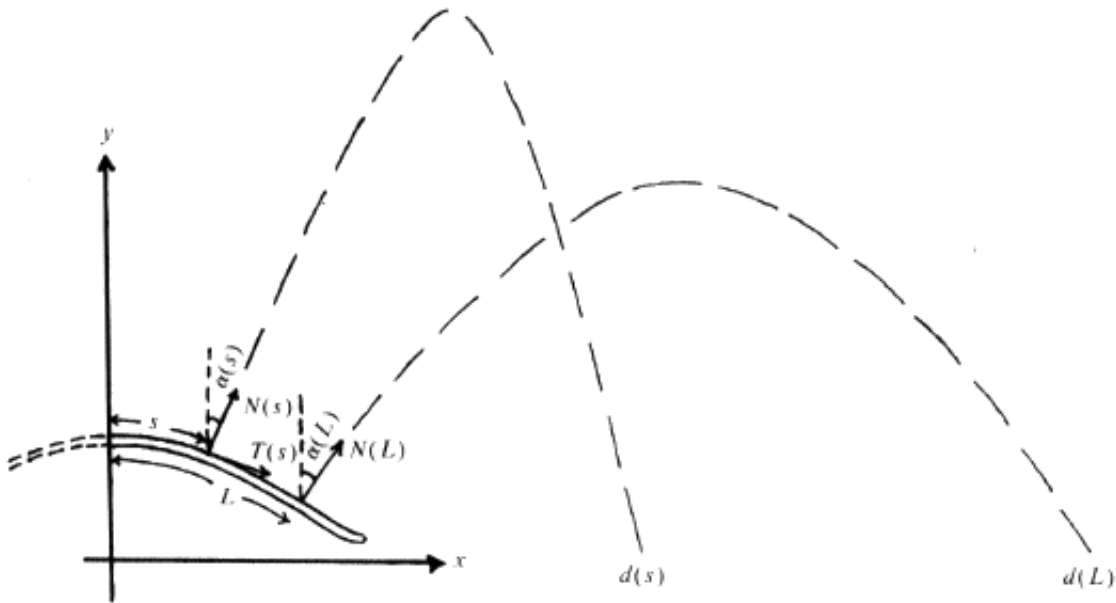

Figure 1

Fortunately, the pair of nonlinear differential equations (2) and (3) for $x(s)$ and $y(s)$ simplifies algebraically:

$$x'^2 + \left(\frac{-ks}{2Lx'}\right)^2 = 1,$$

or

$$x'^4 - x'^2 + \frac{k^2s^2}{4L^2} = 0.$$

Solving by the quadratic formula,

$$x'(s)^2 = \frac{1 \pm \sqrt{1 - \left(\frac{ks}{L}\right)^2}}{2}.$$

Since the sprinkler arm is horizontal at its midpoint, the unit tangent vector $T(0) = \langle x'(0), y'(0) \rangle$ is $\langle 1, 0 \rangle$. Thus $x'(0) = 1$, which means we must use the + sign in the quadratic formula. Substituting

$$x'(s) = \frac{1}{\sqrt{2}} \left[1 + \sqrt{1 - \left(\frac{ks}{L}\right)^2} \right]^{1/2}$$

in equation (2) gives

$$y'(s) = \frac{-1}{\sqrt{2}} \left[1 - \sqrt{1 - \left(\frac{ks}{L}\right)^2} \right]^{1/2}$$

Since $x(0) = 0$ and $y(0)$ is arbitrary, we conclude that

$$x(s) = \frac{1}{\sqrt{2}} \int_0^s \left[1 + \sqrt{1 - \left(\frac{kt}{L}\right)^2} \right]^{1/2} dt$$

and

$$y(s) = y(0) - \frac{1}{\sqrt{2}} \int_0^x \left[1 - \sqrt{1 - \left(\frac{kt}{L}\right)^2} \right]^{1/2} dt.$$

These integrals can be evaluated in closed form, using the identity (kindly supplied by a reviewer)

$$\frac{1 \pm \sqrt{1 - \left(\frac{kt}{L}\right)^2}}{2} = \left[\frac{\sqrt{1 + \frac{kt}{L}}}{2} \pm \frac{\sqrt{1 - \frac{kt}{L}}}{2} \right]^2,$$

with the result

$$x(s) = \frac{L}{3k} \left[\left(1 + \frac{ks}{L}\right)^{3/2} - \left(1 - \frac{ks}{L}\right)^{3/2} \right],$$

$$y(s) = y(0) - \frac{2L}{3k} \left[\left(1 + \frac{ks}{L}\right)^{3/2} + \left(1 - \frac{ks}{L}\right)^{3/2} \right].$$

This sprinkler arm curve is drawn in Figure 2. Note that the curve is determined by the requirement that the streams be evenly spaced along the ground when the plane of the sprinkler arm is vertical. Later we indicate what happens when this plane makes an angle ϕ with the vertical.

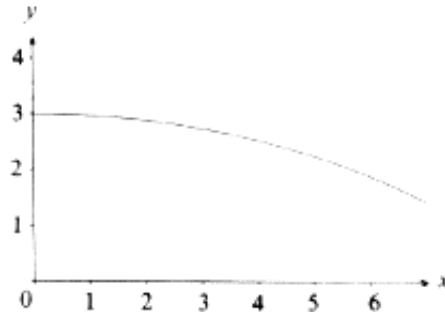

Figure 2

The rocking motion of the sprinkler arm

We wish the sprinkler arm to oscillate in such a way that each stream will deposit water uniformly along its path, or what is the same, the speed of the point of impact of the stream with the ground should be constant on each pass of the sprinkler. As it turns out, this condition cannot be satisfied by all the streams simultaneously, so we shall concentrate our attention on the central stream.

Henceforth, let's choose a coordinate system in space, as indicated in Figure 3, with the z -axis vertical and the axis of rotation of the sprinkler arm the y -axis, with the center of the arm on the positive z -axis. When the plane of the sprinkler arm makes an angle ϕ with the vertical, the central stream will reach the ground on the x -axis, at $x = (v^2/g) \sin 2\phi$. The oscillation of the sprinkler arm is described by the function $\phi(t)$, and the corresponding speed of the central stream over the lawn is the derivative $x'(t) = (2v^2/g) \cos 2\phi(t) \phi'(t)$. Setting $x'(t) = Kv^2/g$, a conveniently labelled constant, we see that uniform coverage by the central stream is equivalent to the requirement that $\phi(t)$ be a solution of the (separable) differential equation

$$2 \cos 2\phi(t) \phi'(t) = K. \quad (4)$$

Integration of (4) gives the solution

$$\sin 2\phi(t) = Kt + c. \quad (5)$$

The parameters K and c have no apparent significance, so we next try to find an expression for the angular variation $\phi(t)$ in terms of two other constants which are easily interpreted.

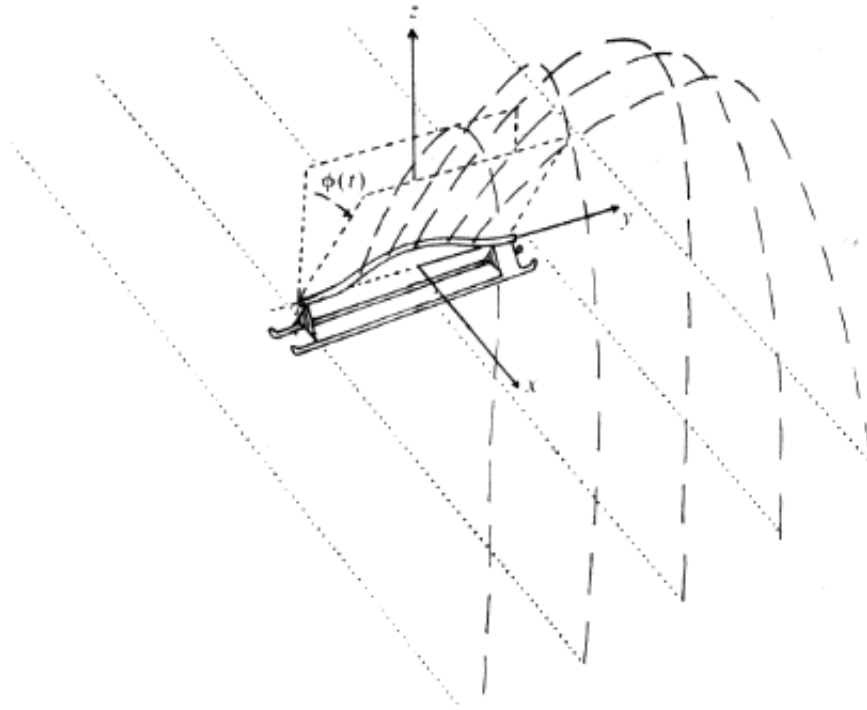

Figure 3

Suppose the sprinkler arm rocks back and forth in the range $-\phi_0 \leq \phi(t) \leq \phi_0$, where the maximum tilt, ϕ_0 , is a design parameter in the range $0 < \phi_0 \leq \pi/4$. Let the time required for the sprinkler arm to rotate between the vertical and the maximum angle ϕ_0 be denoted by T . (Thus $2T$ is the time required for one pass of the sprinkler over the lawn, and $4T$ is the period of the complete oscillation.) If we measure time so that $\phi(0) = -\phi_0$, then setting $t = 0$ in equation (5) gives $c = -\sin 2\phi_0$. Since $\phi(2T) = \phi_0$, we then get $\sin 2\phi_0 = 2KT - \sin 2\phi_0$, or $K = \frac{1}{T} \sin 2\phi_0$. Thus

$$\sin 2\phi(t) = \frac{t - T}{T} \sin 2\phi_0,$$

or, since $-\pi/2 \leq 2\phi(t) \leq \pi/2$,

$$\phi(t) = \frac{1}{2} \arcsin \left[\frac{t - T}{T} \sin 2\phi_0 \right]. \quad (6)$$

The oscillatory motion of the sprinkler arm is therefore uniquely determined (once choices of ϕ_0 and T have been made) by the requirement that the **central** stream cover the ground uniformly.

Remark: Since the maximum range of the central stream occurs when $\phi = \pi/4$, one might think the ideal value for ϕ_0 would be $\pi/4$. However, we will show later that the shape of the region covered by the sprinkler will be more nearly rectangular if ϕ_0 is somewhat smaller than $\pi/4$.

It remains to describe a mechanism which will produce the desired oscillation, given by (6). (It was by observing my own sprinkler, the Nelson “dial-a-rain”, which appears to use the design described below, that I was led to the questions considered in this paper.)

Mechanical design of the sprinkler

The stream of water entering the sprinkler from a hose can be used to turn an impeller (waterwheel), which is then geared down to turn a cam with a constant angular velocity ω . A cam follower linkage converts the uniform rotational motion of the cam into an oscillatory motion of the sprinkler arm—as the cam makes a half-revolution, the sprinkler arm is pushed from $\phi = -\phi_0$ to $\phi = +\phi_0$; and on the next half-revolution of the (bilaterally symmetric) cam, the sprinkler arm makes the return sweep.

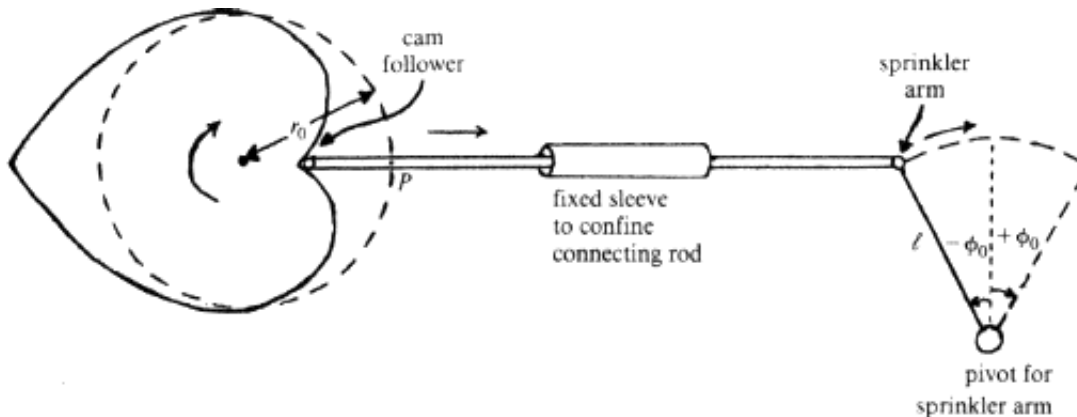

Figure 4. A typical cam mechanism

What shape of cam will cause the oscillation of the sprinkler arm to be that given by (6)? We may describe the shape of a cam in polar coordinates by $r(\theta) = r_0 + f(\theta)$, where the function $f(\theta)$ describes the “eccentricity” of the cam, i.e., its deviation from the circle $r(\theta) = r_0$. The pole of our coordinate system is placed at the center around which the cam rotates, so it is the eccentricity $f(\theta)$ which produces the motion of the sprinkler arm. As the cam follower moves to the right or left of the point labelled P in

Figure 4, by the amount $f(\theta)$, the other end of the connecting rod moves the sprinkler arm the same distance along a circular arc of radius ℓ . Denoting the arclength by s and using the relation $s/\ell = \phi$, we have $f(\theta)/\ell = \phi$. Since $\theta(t) = \omega t$, we want

$$f(\omega t) = \frac{\ell}{2} \arcsin \left[\frac{t - T}{T} \sin 2\phi_0 \right], \quad 0 \leq t \leq 2T.$$

Our goal is to find a formula for the eccentricity $f(\theta)$, so we must express t and T in terms of θ and ω , using the relation $\theta = \omega t$. This is easy: as the cam turns a half-revolution, from $\theta = 0$ to $\theta = \pi$, the sprinkler arm moves from $\phi = -\phi_0$ to $\phi = \phi_0$; so equating the times required gives $\pi/\omega = 2T$. Thus

$$\frac{t - T}{T} = \frac{2\omega t}{\pi} - 1,$$

so

$$f(\omega t) = \frac{\ell}{2} \arcsin \left[\frac{2}{\pi} \left(\omega t - \frac{\pi}{2} \right) \sin 2\phi_0 \right], \quad 0 \leq t \leq 2T.$$

Replacing ωt by θ , we conclude that

$$f(\theta) = \frac{\ell}{2} \arcsin \left[\frac{2}{\pi} \left(\theta - \frac{\pi}{2} \right) \sin 2\phi_0 \right], \quad 0 \leq \theta \leq \pi. \quad (7)$$

As θ goes from π to 2π we want the sprinkler arm to perform the same motion in reverse, i.e., the cam should be symmetric about the polar axis:

$$f(\theta) = f(2\pi - \theta) \text{ for } \pi \leq \theta \leq 2\pi. \quad (8)$$

The polar curve $r(\theta) = r_0 + f(\theta)$, where the eccentricity $f(\theta)$ is given by (7) and (8), is the cam shape which will produce the desired oscillatory motion of the sprinkler arm (see Figure 5). (Note that r_0 is arbitrary, provided $r_0 > \ell\phi_0$.) This curve has an interesting geometric property, described in the following definition.

DEFINITION. A simple closed curve C is said to be of **constant diameter** d if there is a point O inside C such that every chord of C through O has the same length, d . Any chord through this “center” point O is called a **diameter** of C .

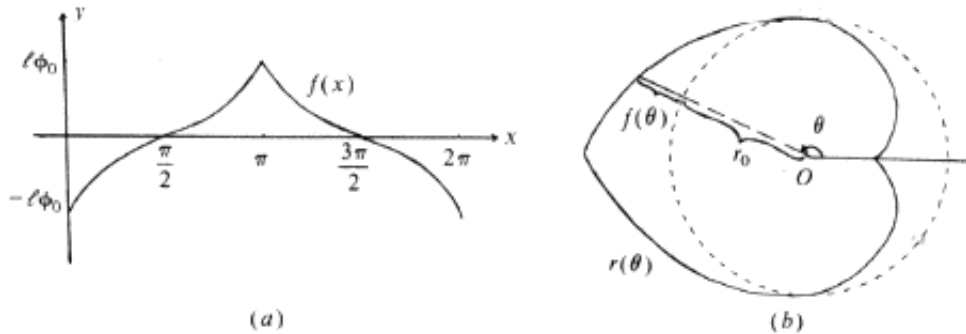

Figure 5

(a) The Cartesian graph of $f(x)$. (b) The polar graph of $r = r_0 + f(\theta)$

N.B. This class of curves should not be confused with “curves of constant width”, a family of **convex** curves which appears frequently in the literature, e.g. [1].

It is easy to verify using (7) and (8), that our cam curve $r(\theta) = r_0 + f(\theta)$ has constant diameter $2r_0$.

Proof. Let O be the pole of our coordinate system. Then the diameter of our curve which makes an angle θ with the polar axis is $r(\theta) + r(\theta + \pi)$, or $2r_0 + f(\theta) + f(\theta + \pi)$. Thus it must be shown that $f(\theta) + f(\theta + \pi) = 0$. Without loss of generality we may assume $0 \leq \theta \leq \pi$; then by (8),

$$\begin{aligned} f(\theta + \pi) &= f(2\pi - (\theta + \pi)) = f(\pi - \theta) \\ &= \frac{\ell}{2} \arcsin \left[\frac{2}{\pi} \left(\pi - \theta - \frac{\pi}{2} \right) \sin 2\phi_0 \right] \\ &= \frac{\ell}{2} \arcsin \left[\frac{-2}{\pi} \left(\theta - \frac{\pi}{2} \right) \sin 2\phi_0 \right] = -f(\theta). \end{aligned}$$

Examining this proof, we discover a simple construction for all curves of constant diameter. Given $d > 0$, take any continuous function $r(\theta)$ such that $r(0) + r(\pi) = d$ and $0 < r(\theta) < d$ for $0 \leq \theta \leq \pi$. If we extend the domain to $[\pi, 2\pi]$ by defining $r(\theta + \pi) = d - r(\theta)$, as in (8), the polar curve $r = r(\theta)$ will have constant diameter d .

For curves symmetric with respect to the polar axis, i.e., with $r(2\pi - \theta) = r(\theta)$ for $0 \leq \theta \leq \pi$, the constant diameter condition is simply that $r(\pi - \theta) = d - r(\theta)$ for $0 \leq \theta \leq \pi/2$. So $d = 2r(\pi/2)$. Thus an arbitrary continuous function $r(\theta)$ defined for $0 \leq \theta \leq \pi/2$, for which $0 < r(\theta) < 2r(\pi/2)$, can be extended uniquely to produce a simple closed curve of constant diameter $d = 2r(\pi/2)$ which is symmetric with respect to the polar axis.

The observation that the cam curve for our sprinkler has constant diameter $2r_0$ suggests a particularly simple mechanical design for the cam follower linkage: a post fixed to the center of the cam, sliding in a slot in the connecting rod, with rollers fixed on the rod separated by the distance $2r_0$. As the cam turns, the rollers remain in contact with it at opposite ends of a diameter, and the connecting rod is alternately pushed and pulled along the line of its slot (see Figure 6). If the cam did not have constant diameter, a more complicated mechanical linkage would be required to keep the cam follower in contact with the cam, and to confine the motion of the connecting rod to one dimension.

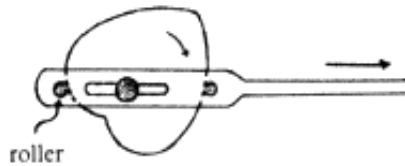

Figure 6

The complete sprinkler pattern

In determining the curve of the sprinkler arm we considered only the situation in which the arm is vertical, and found that the requirement of uniform spacing of the streams on the ground then determines the curve uniquely. Similarly, in analyzing the oscillation of the sprinkler arm we considered only the central stream, and found that the requirement of uniform coverage by this single stream along its path uniquely determines the motion $\phi(t)$. It remains to be seen whether the streams from the other holes will move along the lawn at constant speeds, and whether these streams will remain equally spaced as the sprinkler arm rocks back and forth.

Suppose there are $2n + 1$ holes in the sprinkler arm: one in the center and n more spaced at equal intervals on each side. By symmetry we need only consider the streams from one half of the sprinkler arm. Using the coordinate system described earlier (see Figure 3), denote the angles between the vertical and the streams as they leave the sprinkler arm (when the plane of the arm is vertical) by $\alpha_0, \alpha_1, \dots, \alpha_n$, where $0 = \alpha_0 < \alpha_1 < \dots < \alpha_n \leq \pi/4$. The streams will strike the ground at distances $d_i = (v^2/g) \sin 2\alpha_i$, and since the streams are equally spaced along the ground, $d_i = (i/n)d_n$. That is,

$$\frac{v^2}{g} \sin 2\alpha_i = \frac{i}{n} \left(\frac{v^2}{g} \sin 2\alpha_n \right),$$

$$\text{or, } \alpha_i = \frac{1}{2} \arcsin \left[\frac{i}{n} \sin 2\alpha_n \right].$$

The direction vectors of the streams as they leave the sprinkler arm are $N_i = \langle 0, \sin \alpha_i, \cos \alpha_i \rangle$, $0 \leq i \leq n$.

When the plane of the sprinkler arm is tilted at an angle ϕ , the direction vectors N_j are rotated through the angle ϕ around the y -axis, so the streams issue from the holes in the directions $N_i(\phi) = \langle \cos \alpha_i \sin \phi, \sin \alpha_i, \cos \alpha_i \cos \phi \rangle$. The angle θ_i between $N_i(\phi)$ and the vertical is given by

$$\cos \theta_i = N_i(\phi) \cdot \langle 0, 0, 1 \rangle = \cos \alpha_i \cos \phi,$$

so the i th stream strikes the ground at a distance

$$\begin{aligned} d_i(\theta) &= \frac{v^2}{g} \sin 2\theta_i = \frac{2v^2}{g} \cos \theta_i \sin \theta_i \\ &= \frac{2v^2}{g} \cos \alpha_i \cos \phi \sqrt{1 - \cos^2 \alpha_i \cos^2 \phi}. \end{aligned}$$

The point of impact is $d_i(\phi)\bar{N}_i(\phi)$, where

$$\bar{N}_i(\phi) = \frac{\langle \cos \alpha_i \sin \phi, \sin \alpha_i, 0 \rangle}{\sqrt{\cos^2 \alpha_i \sin^2 \phi + \sin^2 \alpha_i}},$$

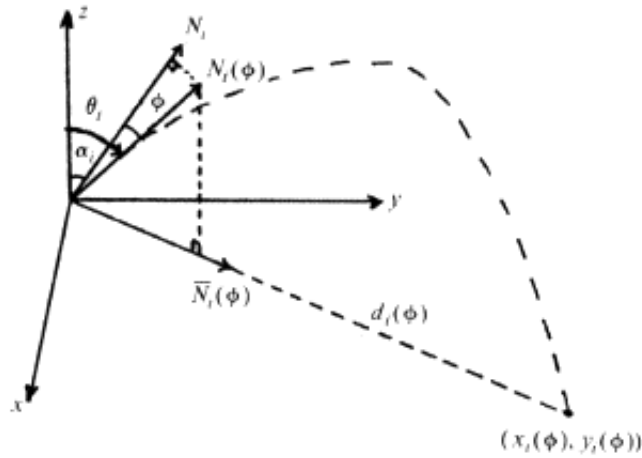

Figure 7

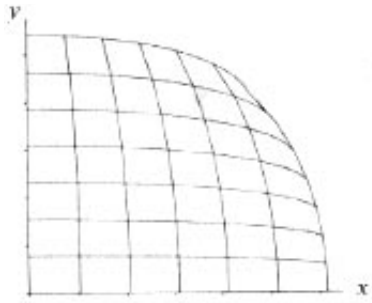

Figure 8

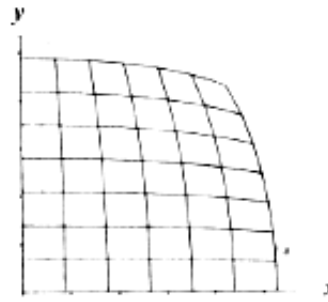

Figure 9

the unit vector in the direction of the projection of $N_i(\phi)$ on the xy plane. Thus parametric equations for the path of the i th stream as it moves over the lawn are

$$x_i(\phi) = \frac{2v^2 \cos^2 \alpha_i \cos \phi \sin \phi \sqrt{1 - \cos^2 \alpha_i \cos^2 \phi}}{g \sqrt{\cos^2 \alpha_i \sin^2 \phi + \sin^2 \alpha_i}},$$

$$y_i(\phi) = \frac{2v^2 \cos \alpha_i \sin \alpha_i \cos \phi \sqrt{1 - \cos^2 \alpha_i \cos^2 \phi}}{g \sqrt{\cos^2 \alpha_i \sin^2 \phi + \sin^2 \alpha_i}}.$$

Evidently $y_i(\phi)$ is not constant, so the path of the i th stream of water is not the straight line parallel to the central stream which one might have expected.

To parametrize the paths by time, we can simply replace the parameter ϕ by the expression for $\phi(t)$ in (6). Computer plots of the resulting family of curves are shown in Figures 8 and 9. In each of these figures, the curves running approximately parallel to the x -axis are the paths of the streams from one side of the sprinkler arm. Time is indicated by the curves nearly parallel to the y -axis, which are polygonal arcs connecting the points on the eight stream paths at six equally spaced instants $T + (k/6)T$, $1 \leq k \leq 6$. (Recall that as t runs through the interval $T \leq t \leq 2T$, the plane of the sprinkler arm turns through the interval $0 \leq \phi \leq \phi_0$.) Thus, each of the resulting “squares” receives the same amount of water on each pass of the sprinkler.

As seen in Figure 8, where $\phi_0 \approx 40^\circ$ and $\alpha_7 \approx 30^\circ$, the outer streams curve in significantly, making the “squares” near the outside corner smaller in area. Since each “square” receives the same amount of water per pass of the sprinkler, the sprinkler shown would overwater the four corners of the region it sprinkled.

In Figure 9, by reducing ϕ_0 to about 29° (and decreasing α_7 to 26° to keep similar proportions to the region watered), not only is the non-uniformity of coverage reduced, but at the same time the region covered is more nearly rectangular.

We conclude with some observations which could not be followed up here; their investigation is left to the proverbial interested reader.

1. No attempt has been made to define an optimal shape for the region watered. Evidently, decreasing the angle parameters ϕ_0 and $\alpha(L)$ will make the coverage more uniform, but at the cost of decreasing the area watered. An interesting question, suggested by a reviewer, might be to design a sprinkler to maximize the area covered without exceeding a stipulated amount of variation in the water applied per unit area. This would mean introducing some non-uniformity along the x and y axes (i.e., unequal spacing of the streams as they strike the ground when the plane of the sprinkler arm is vertical, and non-uniform speed of the central stream along its path), to compensate for the overwatering of the corners observed in Figures 8 and 9 with our sprinkler.
2. My Nelson “dial-a-rain” sprinkler has an additional feature of interest. On the sprinkler arm support is a dial which, when turned, changes the radius ℓ of the arc on which the sprinkler arm moves. The effect of doubling ℓ , for instance, can be shown to be to cut in half the region watered. The coverage of this smaller area is slightly less uniform, however.



*... of course other
sprinkler designs are possible.*

I find it remarkable that not only are the curve of the sprinkler arm and the motion $\phi(t)$ of the arm unique, but even the mechanical design of the sprinkler is essentially determined by the requirement that water should be spread uniformly along the two coordinate axes. The wealth of mathematical questions raised in the analysis of this simple mechanism gives me a new respect for mechanical engineering, and greater confidence in the importance of classical mathematics to students in this field.

Reference

- [1] G.D. Chakerian, A characterization of curves of constant width, Amer. Math. Monthly, 81 (1974) pp. 153–155.